

**WATER COOLED A.C. SWITCH**

**2-2WI-600**

Repetitive voltage up to **1600 V**  
Maximum continuous RMS current **730 A**  
Surge current **5.6 kA**

**FINAL SPECIFICATION**

giu 02 - ISSUE : 01

Symbol	Characteristic	Conditions	T <sub>J</sub> [°C]	Value	Unit
<b>BLOCKING</b>					
V <sub>DRM</sub> /V <sub>RRM</sub>	Repetitive peak voltage		125	1600	V
V <sub>DSM</sub> /V <sub>RSM</sub>	Non-repetitive peak voltage		125	1700	V
I <sub>DRM</sub> /I <sub>RRM</sub>	Repetitive peak current		125	30	mA
<b>CONDUCTING</b>					
I <sub>T(RMS)</sub>	Maximum continuous RMS current	50 Hz, Q = 4 l/min, water temperature = 40°C		730	A
I <sub>TSM</sub>	Surge on-state current	Max peak one cycle sine wave, 10 ms. Without reverse voltage reapplied	125	5.6	kA
I <sup>2</sup> t	I <sup>2</sup> t			157 x1E3	A <sup>2</sup> s
V <sub>TM</sub>	Max peak on-state voltage	ITM = 1032 A	125	1.70	V
V <sub>T(TO)</sub>	Threshold voltage		125	1.00	V
r <sub>T</sub>	On-state slope resistance		125	0.680	mΩ
<b>SWITCHING</b>					
di/dt	Critical rate of rise of on-state current, min.	From 75% V <sub>DRM</sub> up to 1650 A, gate 10 V - 5 Ω	125	200	A/μs
dv/dt	Critical rate of rise of off-state voltage, min.	Linear ramp up to 70% of V <sub>DRM</sub>	125	500	V/μs
<b>GATE</b>					
V <sub>GT</sub>	Gate trigger voltage	VD=5 V	25	3.5	V
I <sub>GT</sub>	Gate trigger current	VD=5 V	25	200	mA
P <sub>GM</sub>	Max peak gate power	Pulse width 100 μs	25	75	W
<b>MECHANICAL</b>					
R <sub>th(j-w)</sub>	Thermal impedance, DC	Junction to water (double side cooled)		0.25	°C/W
V <sub>ins(RMS)</sub>	Insulation voltage rms	1 min	25	2.5	kV
Press	Max water pressure			10	bar
T <sub>J max</sub>	Max operating junction temperature			125	°C
Weight				5050	g
Thermal switch open 63°C, closed 50°C. 10 A - 250 V					

OUTLINE **WO**

DEVICES TYPE: AT505

A	98
B	70

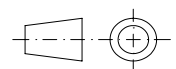
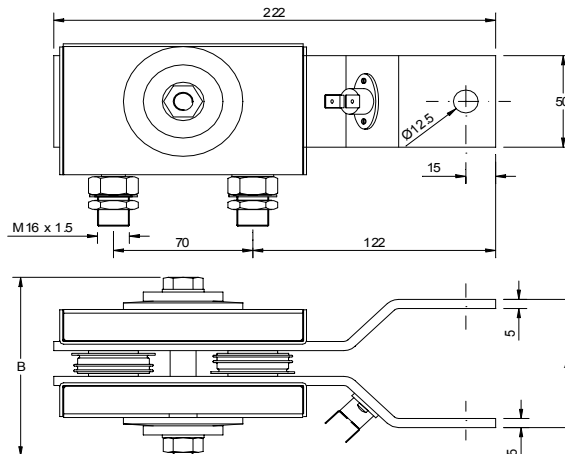
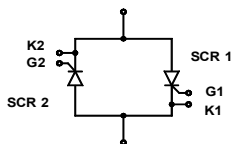

**ORDERING INFORMATION : 2-2WI-600 S 16**

standard specification

VDRM&VRRM/100